

# SWIMMING POOL

R32

## HEAT PUMP UNIT

### *Installation & Instruction Manual*







## Safety Precautions

<p><b>CAUTION</b></p> <hr/> <p><b>R32</b></p> <p><b>REFRIGERANT</b></p> <p>This heat pump contains and operates with refrigerant R32</p> <p><b>THIS PRODUCT MUST ONLY BE INSTALLED OR SERVICED BY QUALIFIED PERSONNEL.</b></p> <p><b>REFER TO NATIONAL AND INTERNATIONAL LEGISLATION, REGULATIONS, CODES, AND INSTALLATION &amp; OPERATION MANUALS FOR THE TRANSPORTATION, STORAGE, INSTALLATION AND /OR SERVICE OF THIS PRODUCT.</b></p>
---





Keep this manual where the user can easily find it.

To prevent personal injury, injury to others, or property damage, read this section carefully before you use this product, and be sure to comply to the following safety precautions.

Incorrect operation due to failure to follow the instructions may cause harm or damage.

 <p><b>WARNING</b></p>	 <p><b>CAUTION</b></p>
<p>Indicate potential hazardous situation, which could result in loss of life or serious injury.</p>	<p>Indicate potential hazardous situation, which could result in moderate injury or damage to property.</p>

### Explanation of symbols displayed on the unit.

	<p>This symbol shows that this appliance uses a flammable refrigerant. If the refrigerant is leaked and exposure to an external ignition source, there is a risk of fire.</p>
	<p>This symbol shows that the Operation Manual should be read carefully.</p>
	<p>This symbol shows that a service personnel should be handling this equipment with reference to the Installation Manual</p>
	<p>This symbol shows that information is available such as the Operating Manual or Installation Manual</p>

After reading, keep this manual in a convenient place so that you can refer to it whenever necessary. If the equipment is transferred to a new user, be sure also to hand over the manual.

	<p><b>WARNING</b></p>
---	-----------------------

Do not use means to accelerate the defrosting process or to clean, other than those recommended by the manufacturer.

The appliance must be stored in a room without continuously operating ignition sources (for example: open flames, an operating gas appliance or an operating electric heater).

Do not pierce or burn.

Be aware that refrigerants may not contain odour.

To avoid fire, explosion or injury, do not operate the unit when harmful gases (e.g. flammable or corrosive) are detected near the unit.

Be aware that prolonged, direct exposure to cool or warm air from the heat pump or to air that is too cool or too warm, can be harmful to your physical condition and health.

Do not place objects, including rods, your fingers, etc., in the air inlet or outlet. Product damage or personal injury may result due to contact with the unit's high-speed fan blades.

Do not attempt to repair, dismantle, reinstall or modify the heat pump yourself as this may result in water leakage, electric shocks or fire hazards.

Do not use flammable sprays near the heat pump, or otherwise fire may result.

Do not use a refrigerant other than the one indicated on the outdoor unit (R32) when installing, moving or repairing. Using other refrigerants may cause trouble or damage to the unit, and personal injury.

To avoid electric shocks, do not operate with wet hands.

Beware of fire in case of refrigerant leakage. If the heat pump is not operating correctly, i.e. not heating, refrigerant leakage could be the cause. Consult your dealer for assistance. The refrigerant within the heat pump is safe and normally does not leak.

However, in the event of a leakage, contact with a naked burner, heater or cooker may result in generation of noxious gas.

Do not use the heat pump until a qualified service person confirms that the leakage has been repaired.

Do not attempt to install or repair the heat pump yourself. Improper workmanship may result in water leakage, electric shocks or fire hazards. Please contact your local dealer or qualified personnel for installation and maintenance work.

If the heat pump is malfunctioning (giving off a burning odours, etc.), turn off power to the unit and contact your local dealer. Continued operation under such circumstances may result in a failure, electric shocks or fire hazards.

Be sure to install an earth leakage circuit breaker. Failure to install an earth leakage circuit breaker may result in electric shocks or fire.

Be sure to earth the unit. Do not earth the unit to a utility pipe, lightning conductor or telephone earth lead. Imperfect earthing may result in electric shocks.

The appliance shall be installed at well ventilated location, the minimum floor area required please refer to national regulation.

Disposal of equipment using flammable refrigerants follow national regulations.

Always follow the local regulations on flammable refrigerant for transportation, storage, installation, repair, etc.



## CAUTION

### 1. Installation (Space)

- That the installation of pipe-work shall be kept to a minimum.
- That pipe-work shall be protected from physical damage.
- That compliance with national gas regulations shall be observed.
- That mechanical connections shall be accessible for maintenance purposes.
- In cases that require mechanical ventilation, ventilation openings shall be kept clear of obstruction.
- When disposing of the product is used, be based on national regulations, properly processed

### 2. Servicing

#### 2-1. Service personnel

- Any person who is involved with working on or breaking into a refrigerant circuit should hold a current valid certificate from an industry-accredited assessment authority, which authorizes their competence to handle refrigerants safely in accordance with an industry recognised assessment specification.
- Servicing shall only be performed as recommended by the equipment manufacturer. Maintenance and repair requiring the assistance of other skilled personnel shall be carried out under the supervision of the person competent in the use of flammable refrigerants.
- Servicing shall be performed only as recommended by the manufacturer.

## 2-2. Work

- Prior to beginning work on systems containing flammable refrigerants, safety checks are necessary to ensure that the risk of ignition is minimised. For repair to the refrigerating system, the precautions in 2-2 to 2-8 shall be complied with prior to conducting work on the system.
- Work shall be undertaken under a controlled procedure so as to minimize the risk of a flammable gas or vapour being present while the work is being performed.
- All maintenance staff and others working in the local area shall be instructed on the nature of work being carried out.
- Work in confined spaces shall be avoided.
- The area around the workspace shall be sectioned off.
- Ensure that the conditions within the area have been made safe by control of flammable material.

## 2-3. Checking for presence of refrigerant

- The area shall be checked with an appropriate refrigerant detector prior to and during work, to ensure the technician is aware of potentially flammable atmospheres.
- Ensure that the leak detection equipment being used is suitable for use with flammable refrigerants, i.e. non sparking, adequately sealed or intrinsically safe.

## 2-4. Presence of fire extinguisher

- If any hot work is to be conducted on the refrigeration equipment or any associated parts, appropriate fire extinguishing equipment shall be available at hand.
- Have a dry powder or CO<sub>2</sub> fire extinguisher adjacent to the charging area.

## 2-5. No ignition sources

- No person carrying out work in relation to a refrigeration system which involves exposing any pipe work that contains or has contained flammable refrigerant shall use any sources of ignition in such a manner that it may lead to the risk of fire or explosion.
- All possible ignition sources, including cigarette smoking, should be kept sufficiently far away from the site of installation, repairing, removing and disposal, during which flammable refrigerant can possibly be released to the surrounding space.
- Prior to work taking place, the area around the equipment is to be surveyed to make sure that there are no flammable hazards or ignition risks. "No Smoking" signs shall be displayed.

## 2-6. Ventilated area

- Ensure that the area is in the open or that it is adequately ventilated before breaking into the system or conducting any hot work.
- A degree of ventilation shall continue during the period that the work is carried out.
- The ventilation should safely disperse any released refrigerant and preferably expel it externally into the atmosphere.

## 2-7. Checks to the refrigeration equipment

- Where electrical components are being changed, they shall be fit for the purpose and to the correct specification.
- At all times the manufacturer's maintenance and service guidelines shall be followed.
- If in doubt consult the manufacturer's technical department for assistance.
- The following checks shall be applied to installations using flammable refrigerants.
  - The charge size is in accordance with the room size within which the refrigerant containing parts are installed.
  - The ventilation machinery and outlets are operating adequately and are not obstructed.
  - If an indirect refrigerating circuit is being used, the secondary circuit shall be checked for the presence of refrigerant.
  - Marking to the equipment continues to be visible and legible. Markings and signs that are illegible shall be corrected.

- Refrigeration pipe or components are installed in a position where they are unlikely to be exposed to any substance which may corrode refrigerant containing components, unless the components are constructed of materials which are inherently resistant to being corroded or are suitably protected against being so corroded.

#### 2-8. Checks to electrical devices

- Repair and maintenance to electrical components shall include initial safety checks and component inspection procedures.
- If a fault exists that could compromise safety, then no electrical supply shall be connected to the circuit until it is satisfactorily dealt with.
- If the fault cannot be corrected immediately but it is necessary to continue operation, an adequate temporary solution shall be used.
- This shall be reported to the owner of the equipment so all parties are advised.
- Initial safety checks shall include.
  - That capacitors are discharged: this shall be done in a safe manner to avoid possibility of sparking.
  - That there no live electrical components and wiring are exposed while charging, recovering or purging the system.
  - That there is continuity of earth bonding.

#### 3.Repairs to sealed components

- During repairs to sealed components, all electrical supplies shall be disconnected from the equipment being worked upon prior to any removal of sealed covers, etc.
- If it is absolutely necessary to have an electrical supply to equipment during servicing, then a permanently operating form of leak detection shall be located at the most critical point to warn of a potentially hazardous situation.
- Particular attention shall be paid to the following to ensure that by working on electrical components, the casing is not altered in such a way that the level of protection is affected.
- This shall include damage to cables, excessive number of connections, terminals not made to original specification, damage to seals, incorrect fitting of glands, etc.
- Ensure that apparatus is mounted securely.
- Ensure that seals or sealing materials have not degraded such that they no longer serve the purpose of preventing the ingress of flammable atmospheres.
- Replacement parts shall be in accordance with the manufacturer's specifications.

NOTE: The use of silicon sealant may inhibit the effectiveness of some types of leak detection equipment. Intrinsically safe components do not have to be isolated prior to working on them.

#### 4.Repair to intrinsically safe components

- Do not apply any permanent inductive or capacitance loads to the circuit without ensuring that this will not exceed the permissible voltage and current permitted for the equipment in use.
- Intrinsically safe components are the only types that can be worked on while live in the presence of a flammable atmosphere.
- The test apparatus shall be at the correct rating.
- Replace components only with parts specified by the manufacturer.
- Other parts may result in the ignition of refrigerant in the atmosphere from a leak.

#### 5.Cabbling

- Check that cabling will not be subject to wear, corrosion, excessive pressure, vibration, sharp edges or any other adverse environmental effects.
- The check shall also take into account the effects of aging or continual vibration from sources such as compressors or fans.

#### 6. Detection of flammable refrigerants

- Under no circumstances shall potential sources of ignition be used in the searching for or detection of refrigerant leaks.
- A halide torch (or any other detector using a naked flame) shall not be used.

#### 7. Leak detection methods

- Electronic leak detectors shall be used to detect flammable refrigerants, but the sensitivity may not be adequate, or may need re-calibration. (Detection equipment shall be calibrated in a refrigerant-free area.)
- Ensure that the detector is not a potential source of ignition and is suitable for the refrigerant used.
- Leak detection equipment shall be set at a percentage of the LFL of the refrigerant and shall be calibrated to the refrigerant employed and the appropriate percentage of gas (25 % maximum) is confirmed.
- Leak detection fluids are suitable for use with most refrigerants but the use of detergents containing chlorine shall be avoided as the chlorine may react with the refrigerant and corrode the copper pipe-work.
- If a leak is suspected, all naked flames shall be removed/extinguished.
- If a leakage of refrigerant is found which requires brazing, all of the refrigerant shall be recovered from the system, or isolated (by means of shut off valves) in a part of the system remote from the leak. Oxygen free nitrogen (OFN) shall then be purged through the system both before and during the brazing process.

#### 8. Removal and evacuation

- When breaking into the refrigerant circuit to make repairs – or for any other purpose – conventional procedures shall be used. However, it is important that best practice is followed since flammability is a consideration.

The following procedure shall be adhered to:

- remove refrigerant
- purge the circuit with inert gas
- evacuate
- purge again with inert gas
- open the circuit by cutting or brazing
- The refrigerant charge shall be recovered into the correct recovery cylinders.
- The system shall be “flushed” with OFN to render the unit safe.
- This process may need to be repeated several times.
- Compressed air or oxygen shall not be used for this task.
- Flushing shall be achieved by breaking the vacuum in the system with OFN and continuing to fill until the working pressure is achieved, then venting to atmosphere, and finally pulling down to a vacuum.
- This process shall be repeated until no refrigerant is within the system.
- When the final OFN charge is used, the system shall be vented down to atmospheric pressure to enable work to take place.
- This operation is absolutely vital if brazing operations on the pipe work are to take place.
- Ensure that the outlet for the vacuum pump is not close to any ignition sources and there is ventilation available.

#### 9. Charging procedures

- In addition to conventional charging procedures, the following requirements shall be followed.
  - Ensure that contamination of different refrigerants does not occur when using charging equipment.
  - Hoses or lines shall be as short as possible to minimize the amount of refrigerant contained in them.
  - Cylinders shall be kept upright.
  - Ensure that the refrigeration system is earthed prior to charging the system with refrigerant.

- Label the system when charging is complete (if not already).
- Extreme care shall be taken not to overfill the refrigeration system.
- Prior to recharging the system it shall be pressure tested with OFN.
- The system shall be leak tested on completion of charging but prior to commissioning.
- A follow up leak test shall be carried out prior to leaving the site.

#### 10. Decommissioning

- Before carrying out this procedure, it is essential that the technician is completely familiar with the equipment and all its details.
- It is recommended good practice that all refrigerants are recovered safely.
- Prior to the task being carried out, an oil and refrigerant sample shall be taken in case analysis is required prior to re-use of reclaimed refrigerant.
- It is essential that electrical power is available before the task is commenced.
  - a) Become familiar with the equipment and its operation.
  - b) Isolate system electrically.
  - c) Before attempting the procedure ensure that:
    - mechanical handling equipment is available, if required, for handling refrigerant cylinders;
    - all personal protective equipment is available and being used correctly;
    - the recovery process is supervised at all times by a competent person;
    - recovery equipment and cylinders conform to the appropriate standards.
  - d) Pump down refrigerant system, if possible.
  - e) If a vacuum is not possible, make a manifold so that refrigerant can be removed from various parts of the system.
  - f) Make sure that cylinder is situated on the scales before recovery takes place.
  - g) Start the recovery machine and operate in accordance with manufacturer's instructions.
  - h) Do not overfill cylinders. (No more than 80 % volume liquid charge).
  - i) Do not exceed the maximum working pressure of the cylinder, even temporarily.
  - j) When the cylinders have been filled correctly and the process completed, make sure that the cylinders and the equipment are removed from site promptly and all isolation valves on the equipment are closed off.
  - k) Recovered refrigerant shall not be charged into another refrigeration system unless it has been cleaned and checked.

#### 11. Labelling

- Equipment shall be labelled stating that it has been de-commissioned and emptied of refrigerant.
- The label shall be dated and signed.
- Ensure that there are labels on the equipment stating the equipment contains flammable refrigerant.

#### 12. Recovery

- When removing refrigerant from a system, either for servicing or decommissioning, it is recommended good practice that all refrigerants are removed safely.
- When transferring refrigerant into cylinders, ensure that only appropriate refrigerant recovery cylinders are employed.
- Ensure that the correct number of cylinders for holding the total system charge are available.
- All cylinders to be used are designated for the recovered refrigerant and labelled for that refrigerant (i.e. special cylinders for the recovery of refrigerant).
- Cylinders shall be complete with pressure relief valve and associated shut-off valves in good working order.



- Empty recovery cylinders are evacuated and, if possible, cooled before recovery occurs.
- The recovery equipment shall be in good working order with a set of instructions concerning the equipment that is at hand and shall be suitable for the recovery of flammable refrigerants.
- In addition, a set of calibrated weighing scales shall be available and in good working order.
- Hoses shall be complete with leak-free disconnect couplings and in good condition.
- Before using the recovery machine, check that it is in satisfactory working order, has been properly maintained and that any associated electrical components are sealed to prevent ignition in the event of a refrigerant release. Consult manufacturer if in doubt.
- The recovered refrigerant shall be returned to the refrigerant supplier in the correct recovery cylinder, and the relevant Waste Transfer Note arranged.
- Do not mix refrigerants in recovery units and especially not in cylinders.
- If compressors or compressor oils are to be removed, ensure that they have been evacuated to an acceptable level to make certain that flammable refrigerant does not remain within the lubricant.
- The evacuation process shall be carried out prior to returning the compressor to the suppliers.
- Only electric heating to the compressor body shall be employed to accelerate this process.
- When oil is drained from a system, it shall be carried out safely.

## Advice to customers

1. Please read this manual carefully before installing the product, otherwise you could damage the heat pump, injure users or incur financial losses.
2. As advances in science and technology are made, the product will also improve.  
We would therefore urge you to keep up to date with the latest products.
3. If you require further technical information, please contact your local distributor.
4. Note:
  - 4.1 Before installing the heat pump, check that your local power supply meets the requirements of the heat pump.  
For full details, check the unit's label or the performance information that appears in this manual.
  - 4.2 Fit the electrical protection devices in compliance with local regulations.
  - 4.3 You must earth the heat pump in order to prevent electric shocks caused by an unexpected short circuit in the unit.
  - 4.4 There is a diagram of the wiring in this manual.
  - 4.5 For safety reasons, you should not replace or repair the heat pump yourself. If it required repairs, please contact your local distributor for assistance.
  - 4.6 Do not place objects inside the heat pump while it is working. They could come into contact with the fan and damage it, as well as cause accidents (especially in the case of children).
  - 4.7 Do not use the heat pump without the grille or plaque, as this could cause accidents or the unit to malfunction.
  - 4.8 If the unit fills with water, contact your local distributor immediately.  
The unit may only be reset following a full inspection by a qualified service engineer.
  - 4.9 Unqualified service engineers may not adjust the unit's switchboards, valves or controllers.

**\*This appliance can be used by children aged from 8 years and above and persons with reduced physical, sensory or mental capabilities or lack of experience and knowledge if they have been given supervision or instruction concerning use of the appliance in a safe way and understand the hazards involved.  
Children shall not play with the appliance.  
Cleaning and user maintenance shall not be made by children without supervision.**

# Contents

1. Performance and installation.....	1
1.1 Performance and features.....	1
1.2 Working principles.....	1
1.3 Location of heat pump installation.....	2
1.4 First time start-up.....	3
1.5 Condensation.....	3
1.6 Accessories.....	3
2. Dimension .....	4
3. Specifications.....	4
4. Operation instruction.....	5
5. Maintenance and inspection.....	6
5.1 Maintenance .....	6
5.2 Trouble shooting guide .....	6
5.3 Parameter table overview .....	
5.4 Failure code table overview.....	7
6. Name plate & wiring diagram .....	9
6.1 Name plate .....	9
6.2 Wiring diagram .....	10

# 1. Performance and installation

## 1.1 Performance and features

### ✓ High efficiency

With a COP value up to 5.0 our heat pumps are very efficient when transferring heat from the air to the swimming pool water. You can save as much as 80% of cost compared to an electrical heater.

### ✓ Long life-span

The heat exchanger is made of PVC & Titanium tube, which can withstand and prolong exposure to swimming pool water.

### ✓ Easy control and operation

The unit is very easy to operate: simply switch it on and set the desired pool water temperature. The system includes a micro-computer controller, allowing all operation parameters to be set. Operation status can be displayed on the controller with LED display.

## 1.2 Working principles

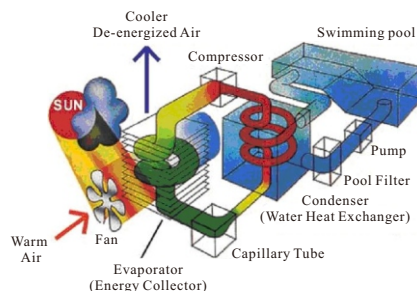
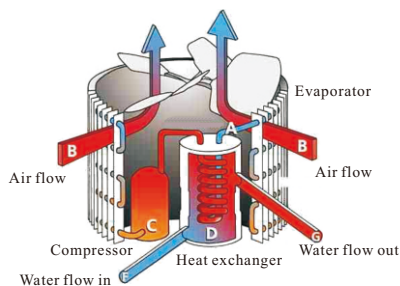

### ✓ Heat pumps utilize the sun's free heat by collecting and absorbing energy from the outside air.

This energy is then compressed and transferred to the pool water. Your existing water pump circulates the water through the heater, usually next to the pool equipment, and the water warms up. The heat pump timer can be set to operate during daylight hours, for example, usually 9am to 5pm.

### ✓ The unit contains a fan that draws in outside air and directs it over the surface of the EVAPORATOR (energy collector). The liquid refrigerant within the EVAPORATOR coil absorbs the heat from the outside air becomes a gas.

### ✓ The warm gas in the coil passes through the COMPRESSOR concentrating and increasing the heat to form a very hot gas which then passes to the CONDENSER (water heat exchanger). It is here that the heat exchange occurs as the hot gas gives off heat to the cool swimming pool water circulating through the coil.

### ✓ The pool water becomes warmer, and the hot gas cooling as it flows through the CONDENSER coil returns to its liquid form and, after passing on through the CAPILLARY TUBE, the whole process begins again.

### ✓ The state of the heat pump technology can efficiently collect heat from the outside air down to the 7°C to 10 range. For tropic and subtropical climates, this means that the pool can be maintained at 26°C to 32°C

## 1.3 Location of heat pump installation

The unit will perform well on any location provided three factors are present:

### 1. Fresh air - 2. Electricity - 3. Pool filter piping

The unit may be installed virtually anywhere outdoors providing minimum distance requirements are met with respect to other objects (see diagram below). For indoor pools please consult your installer. If the unit is placed in a windy area, no problems occur with e.g. the pilot light, as opposed to what is often the case with gas heaters.

Attention: Do not place the unit in an enclosed area with a limited air volume where the unit's discharged air will be re-circulated or near shrubs that could block the air inlet. These locations deny the unit a continuous fresh air supply, which reduces its efficiency and may prevent adequate heat yield. See diagram below for minimum required distances.

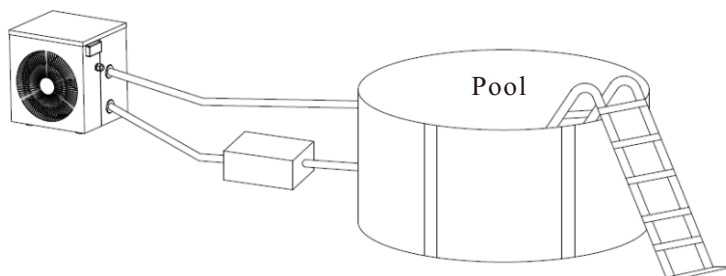

### Cautions

- Do not put your hands or any other object into the air outlet and fan. It could damage the heat pump and cause injuries.
- In case any abnormality was found in the heat pump, please cut off the power at once and contact a professional technician.
- It is strongly suggested to place a guard around the machine to keep children away from the heat pump.

## 1.4 First time start-up

**Note- In order for the unit to heat the pool (or spa), the filter pump must be running so that the water can circulate through the heat pump. Without this circulation, the heat pump will not start.**

When all connections have been made and checked, the following steps should be followed:



- 1). Turn on the filter pump. Check for leaks.
- 2). Turn on the electrical power supply to the unit, then press the ON/OFF key on the electronic control panel. The unit should start when the time delay period has elapsed.
- 3). When the unit has been running for a couple of minutes, check if the air leaving the unit is cooler than the ambient temp.
- 4). Check the performance of the flow switch as follows: with the unit running turn the filter pump off. The unit should also switch off automatically.
- 5). The unit and the filter pump should run 24 hours a day until the desired pool water temperature has been reached. Once the set temperature is reached, the unit will switch itself off. As long as the filter pump is running, the unit will restart automatically when the temperature of the pool water drops more than 1°C below the set temperature.

Depending on the starting temperature of the pool water and the air temperature, it can take several days for the water to reach the desired temperature. Covering the pool can drastically reduced this period.

## 1.5 Condensation

When the swimming pool water is being heated by the heat pump, the incoming air is cooled down quite a bit, which can cause condensation on the fins of the evaporator. Condensed volumes can attain several litres per hour under high atmospheric humidity. Sometimes, this is wrongfully interpreted as a water leak.

## 1.6 Accessories

Accessory	Rerefence	Quantity
Connector		2
Hose clamp		2

## 2. Dimension

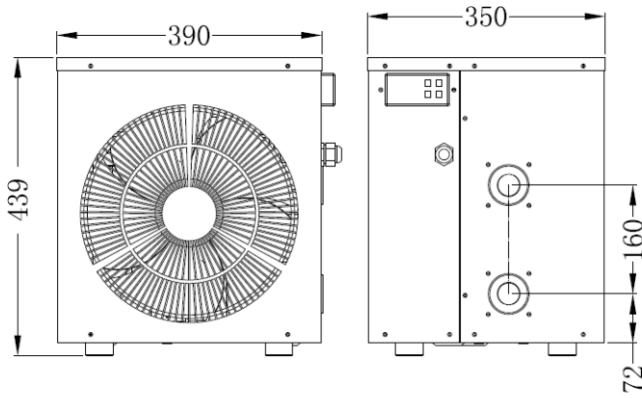

## 3. Specifications

Model		AGMINI
Advised pool volume	m <sup>3</sup>	<20
Ambient temperature range	°C	10~43
Heating capacity	kW	2.9
COP	-	4.9
Running current heating	A	2.83
Refrigerant Type	-	R32
Water Flow Rate	m <sup>3</sup> /h	1.3
Power Supply	V/PH/HZ	220~240/1/50
Net Dimension (L*W*H)	mm	420*350*440
Net Weight	kg	23

## 4.Operation instruction



### Icon illustration

Red indicator light on after switch on the power.

Green indicator light on after compressor start.

When switched off the screen display “OFF” , all indicators off.

When switched on the screen display inlet water temperature.

When there is failure display error code.



### On/off button:

From home page press  to switch on/off the heat pump. .

From parameters page press  to return to home page.

### “Set” button

Press “Set” 5S to check parameters, use “▲” “▼” to scroll to other parameters.

From parameters page, press “Set” to change the setpoint (the parameter will flashing) , use “▲” “▼” to change the setpoint, then press “Set” again to return to parameter page.

### “▲” “▼” Page up/down button

From home page press “▲” “▼” to change desired temperature setpoint.



## 5. Maintenance and inspection

### 5.1 Maintenance

- ✓ Check the water inlet and drainage often. The water and air inflow into the system should be sufficient so that its performance and reliability does not get compromised. You should clean the pool filter regularly to avoid damage to the unit caused by clogging of the filter.
- ✓ The area around the unit should be spacious and well ventilated. Clean the sides of the heat pump regularly to maintain good heat exchange and to save energy.
- ✓ Check if all processes in the unit are operational and pay special attention to the operation pressure of the refrigerant system.
- ✓ Check the power supply and cable connections regularly. Should the unit begin to function abnormally or should you notice a smell from an electrical component, arrange for timely repair or replacement.
- ✓ You should also purge the water if the unit will not work for an extended period of time. You should check all parts of the unit thoroughly and completely fill the system with water before turning it on again afterwards.

### 5.2 Failure code table overview

Control Display	Protection/Failure	Check	Solution
P1	Inlet water temp. sensor failure	1. Check the connection of inlet water sensor. 2. Check if the sensor is broken.	1. Reconnect the sensor. 2. Replace the sensor.
P2	Ambient temp. sensor failure	1. Check the connection of outlet water sensor. 2. Check if the sensor is broken.	1. Reconnect the sensor. 2. Replace the sensor.
P3	Ambient temp. too low	1. Check if the sensor is broken 2. Check if the ambient temp. is less than 10 °C.	1. Replace the sensor. 2. Stop use the heat pump.
P5	High pressure protection	1. Check if high pressure switch is broken. 2. Check if there is a blockage in water circuit or water flow is not enough. 3. Check if there is a blockage in refrigerant circuit.	1. Replace high pressure switch. 2. Remove cause of blockage or increase water flow. 3. Send heat pump to dealer for detailed check.
P5	High pressure switch failure	1. Check the connection of pressure switch 2. Check if the switch is broken.	1. Reconnect the switch. 2. Replace the switch.

### 5.3 Parameter table overview

Parameter	Control Display	Range	Default	Remark
A	Temp. Setting Heating	15~40°C	28°C	Adjustable
B	Delta T for heat pump restart	1~10°C	2°C	Adjustable
C	Ambient temp. too low setpoint	0~15°C	2°C	Adjustable
D	Delta T for too low ambient temp	1~15°C	2°C	Adjustable
E	Power loss memory	0/1	1(Yes)	Adjustable
F	Temp. calibration	-15~15°C	0	Adjustable
H	Inlet water temp	-19~99°C		Actual value
L	Outlet water temp	-19~99°C		Actual value

## 5.4 Trouble shooting guide

Incorrect installation may result in an electrical charge that could lead to death or serious injury of users, installers or others by electrical shock and it may also cause damage to heat pump.

**DO NOT** attempt to modify the internal configuration of the heat pump.

1. Keep your hands and hair clear of the fan blades to avoid injury.
2. If you are not familiar with your pool filtration system and heat pump:
  - a. **Do not** attempt to carry out any adjustment or service without consulting your dealer, pool professional or air conditioning contractor.
  - b. Read the entire installation manual before attempting to use, service or make adjustments to the unit.
  - c. Wait for 24 hours after the installation before start the heat pump to prevent damage to the compressor. (If the heat pump has been transported and carried all the time with the feet down, it can be started immediately).

Note: Switch off the power before carrying out any maintenance or repairs

**IMPORTANT REMARK:** if a malfunction cannot be resolved immediately, in order to analyse the problem we will need to know the message (error code) that is showing on the display controller as well as the values for the settings. We also need to know the status of the heat pump : the ambient temperature, water inlet / outlet temperature, if it is cold air coming out from the heat pump, if the grill (Evaporator) is cold, or if there is ice on the heat pump.

Please keep this information at hand when calling customer service (describe the issue).

On the following pages you will find an overview of the different types of failure problems that can occur together with instructions on how to solve them.

Problem :	the heat pump doesn't work
Observation:	the screen does not light up and the fan/compressor doesn't make a sound
Possible cause	Solution
No electrical power supply	Check power supply (wiring, fuses, ……………)

Problem :	the heat pump works normally but there is no or insufficient heating
Observation:	The screen displays the temperature but no error codes
Possible cause	Solution
1. In sufficient capacity of the heat pump in proportion to the size of the swimming pool	1. Install a larger sized model or an extra heat pump. Cover the pool to limit heat loss
2. The compressor works but the fan doesn't	2. Check the electrical wiring of the fan. Replace the condenser or the fan motor if necessary.
3. The fan works but the compressor doesn't	3. Check the electrical wiring of the compressor. Replace the condenser or the compressor if necessary.
4. The heat pump has not been placed on an optimal location	4. Make for sufficient air circulation(see manual for details)
5. Faulty temperature setting	5. Set the correct temperature
6. By-pass not adjusted	6. Have the by-pass readjusted by the installer
7. Massive ice formation on the evaporator	7. Have the settings for automatic defrost control checked by the installer
8. Not enough refrigerant	8. Have the heat pump checked by a refrigeration technician

<b>Problem:</b>	The heat pump works normally but the water is cooling down instead of heating up	
<b>Observation:</b>	The screen displays the temperature but no error codes	
	<b>Possible cause</b>	<b>Solution</b>
	1.The wrong mode has been selected	1.Verify the parameters, select the correct mode
	2. The controller is out of order	2. Check the voltage in the electrical wiring to the 4-way valve. If no electric potential is measured, replace the controller
	3. The 4-way valve is out of order	3. Check the voltage in the electrical wiring to the 4-way valve. If electric potential is measured, replace the coil. If the problem persists, have the heat pump checked by a refrigeration technician

<b>Problem:</b>	the heat pump doesn't stop	
<b>Observation:</b>	the screen displays the temperature but no error codes	
	<b>Possible cause</b>	<b>Solution</b>
	1.Wrong setting of parameters	1.Check the set parameters and adjust them if necessary (settings just above the capacity of the heat pump)
	2. Pressure switch out of order	2. Check operation of the pressure switch by turning off the filter pump and restarting it. If the heat pump doesn't react to this, the pressure switch must be adjusted or replaced.
	3. Electrical failure	3. Contact your installer

<b>Problem:</b>	water leak	
<b>Observation:</b>	there's an amount of water under the heat pump	
	<b>Possible cause</b>	<b>Solution</b>
	1.Condensation due to atmospheric humidity	1.No action required
	2.Water leak	2.Try to localize the leak and check for the presence of chlorine in the water. If that is the case, the heat pump must be temporarily replaced during repair.

<b>Problem:</b>	abnormal amount of ice formed on the evaporator	
<b>Observation:</b>	the evaporator is for the most part covered in ice	
	<b>Possible cause</b>	<b>Solution</b>
	1.Insufficient air inflow	1.Check the location of the heat pump and remove any dirt that could be present on the evaporator
	2.High water temperature	2.If the pool water is already quite hot (warmer than 29°),the probability of ice formation increases. Lowering the set temperature is a possible option
	3.Incorrect setting of automatic defrost control	3.Check the setting of the defrosting function together with your installer.
	4.The 4-way valve is out of order	4.Check the voltage in the electrical wiring to the 4-way valve. If electric potential is measured, replace the coil. If the problem persists, have the heat pump checked by a refrigeration technician.
	5.Not enough refrigerant	5.Have the heat pump checked by a refrigeration technician.

**6.Name plate & wiring diagram**

6.1Name plate

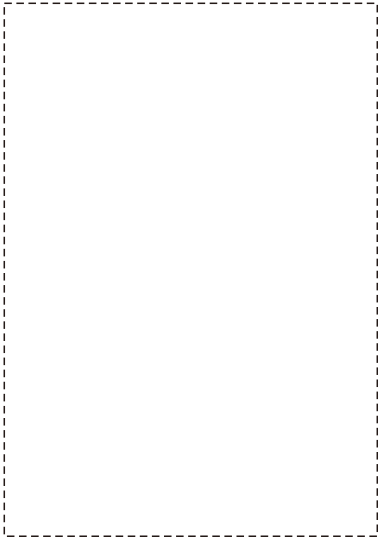

## 6.2 Wiring diagram



